

Precision for automotive industry

Laser measurement for blanking lines:
Thickness, contour and flatness



alpha.xi compact

Measurement of automotive blanks checked against DXF drawing

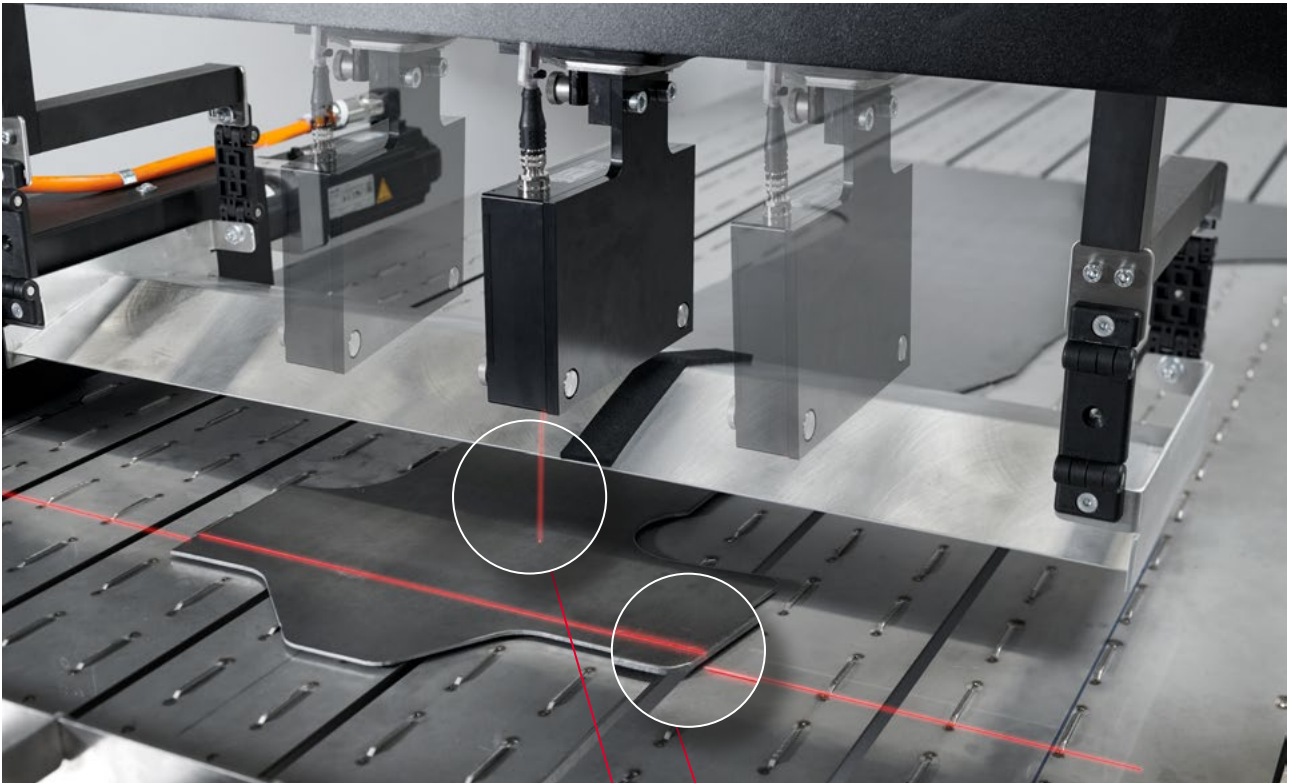

Thickness measurement

With one track;
can be expanded up to six tracks in parallel

Contour and flatness measurement

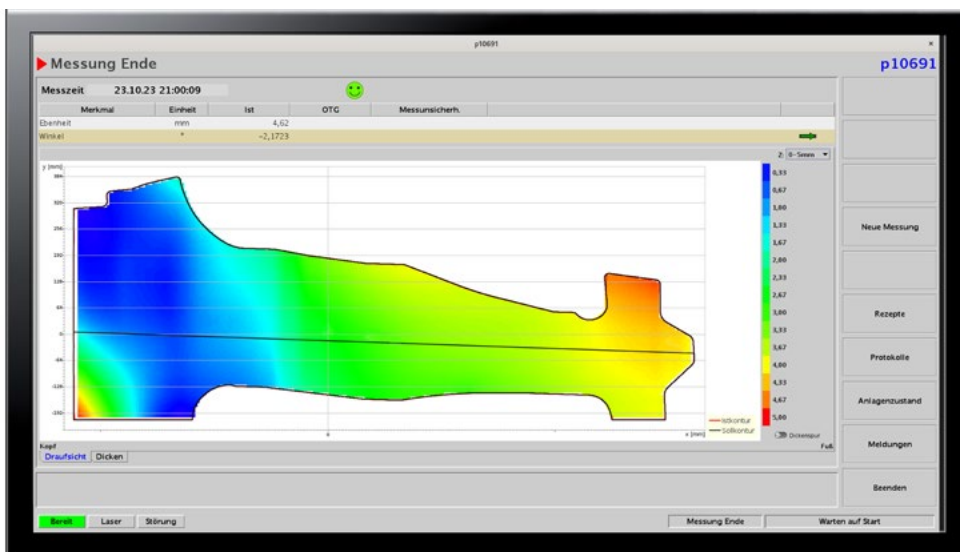

Display of measurement results for thickness, contour and flatness

